

## Klein, kleiner, Hörgerät: Hardwaredesign mit Herausforderungen



## Hörgerätelösning



Hörgerät



Ladegerät



App



Tools



## Hörgerät Komponenten

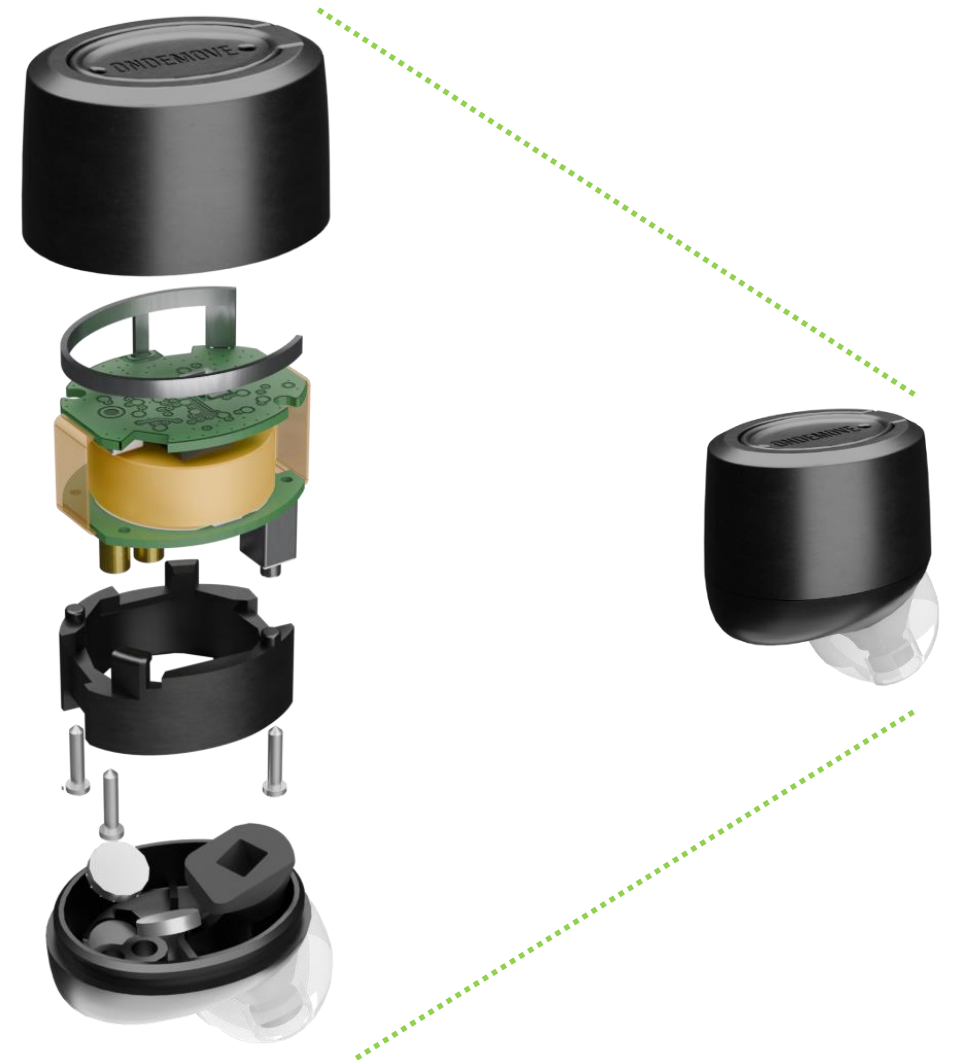
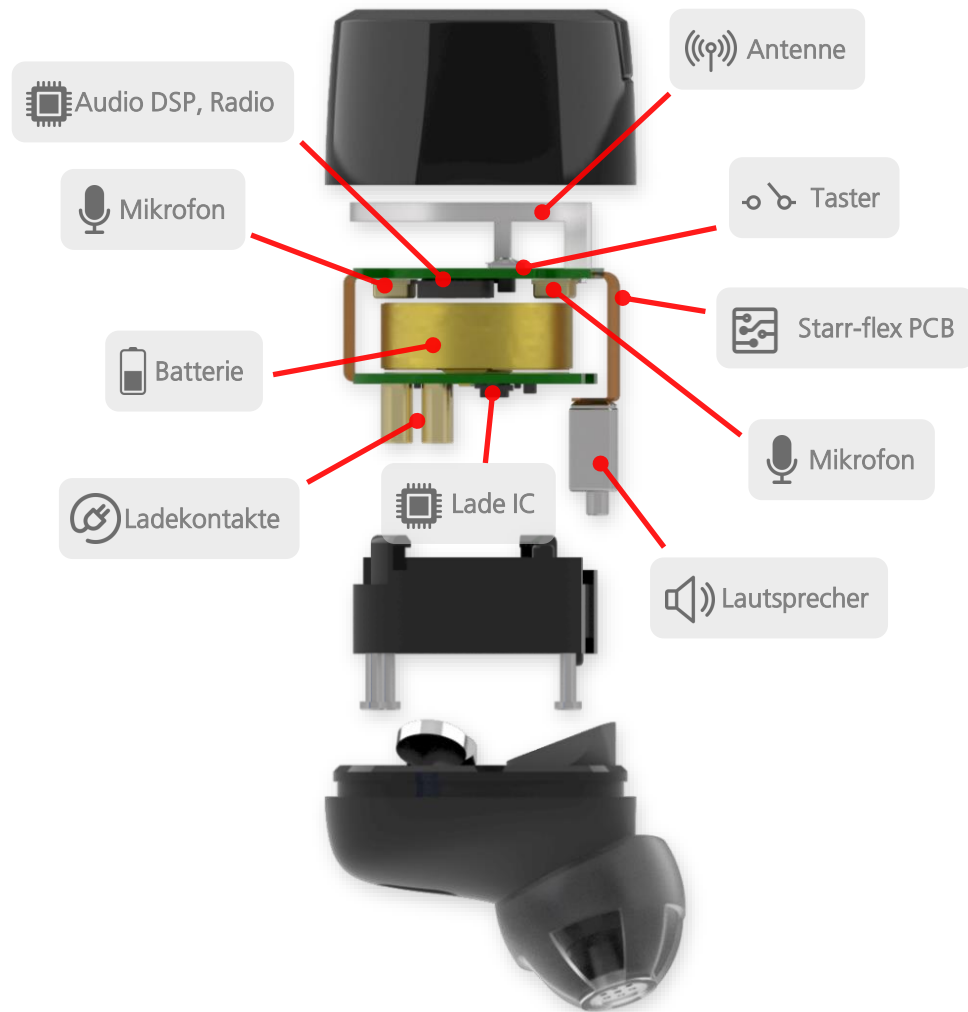

## Hörgerät

Blockschaltbild

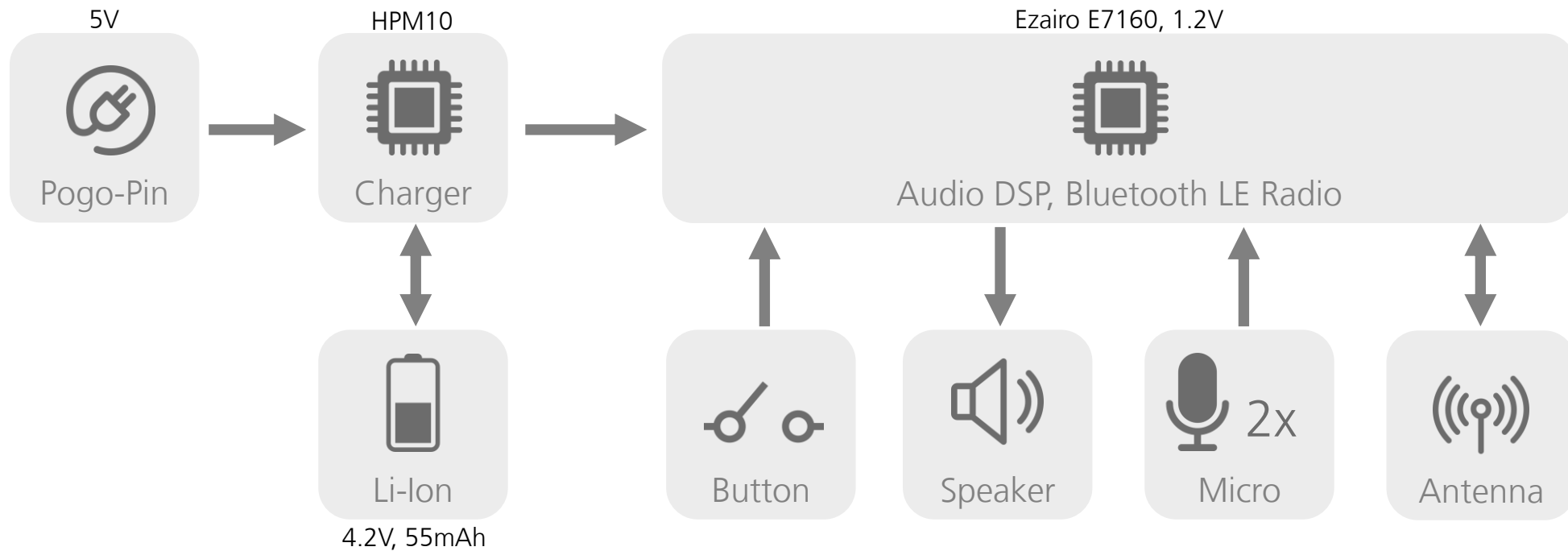
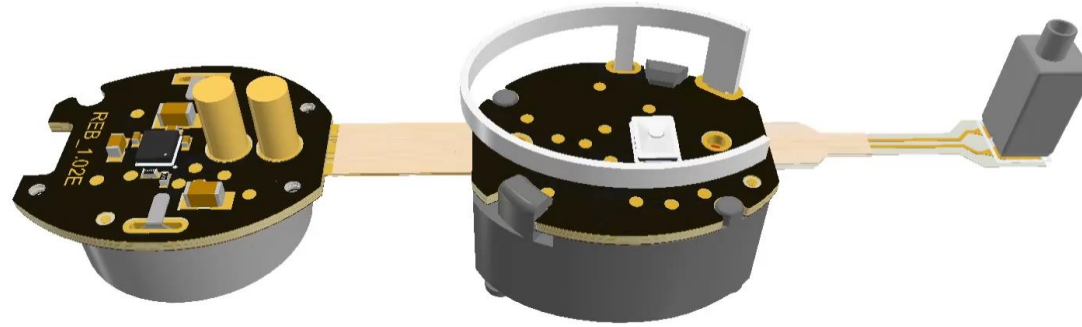

## Hörgerät

### Antennendesign

#### Antennen-Seite

Frei von metallischen Objekten

#### Unterseite

Platzieren von metallischen Objekten und störanfälligen Bauteilen.

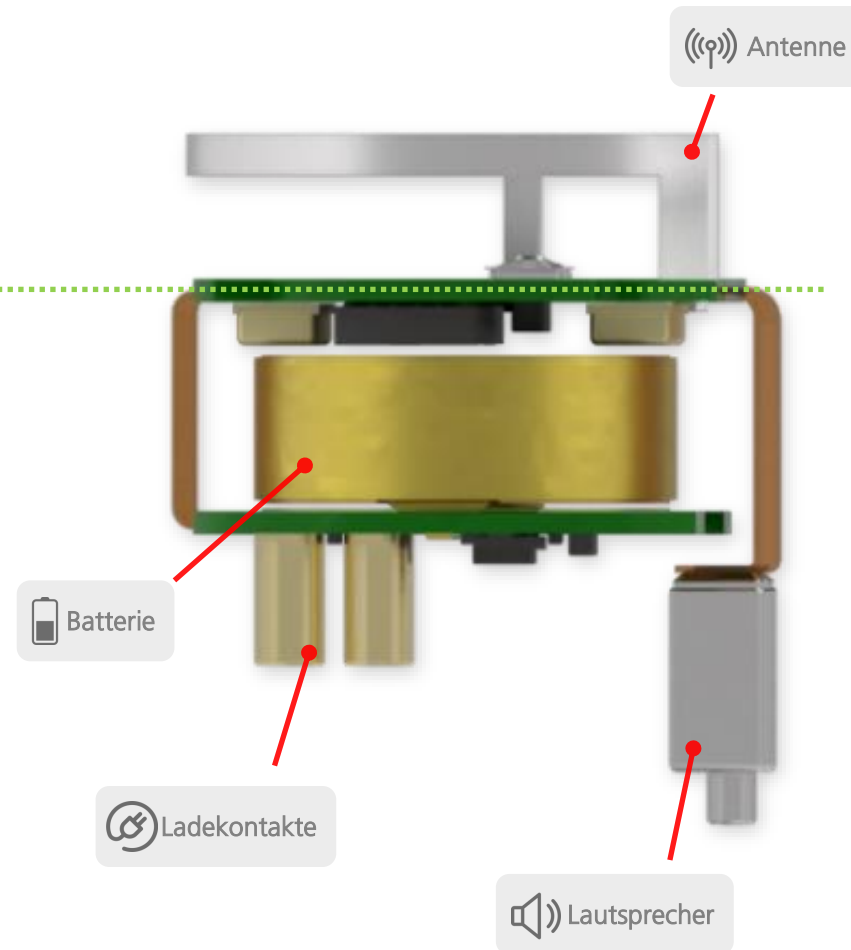

## Hörgerät

Simulation

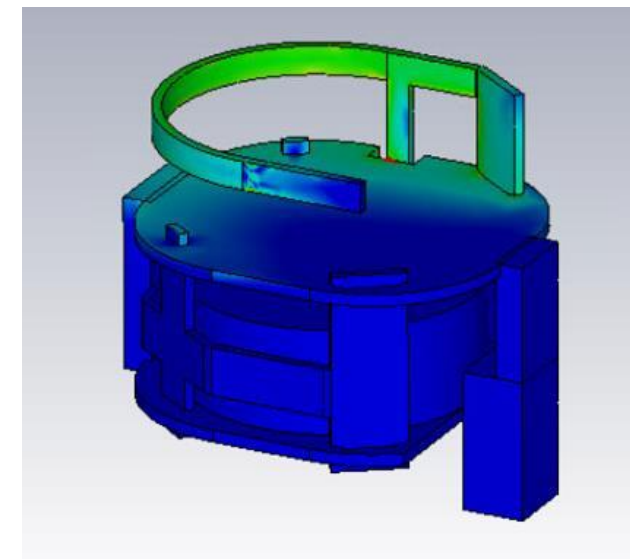
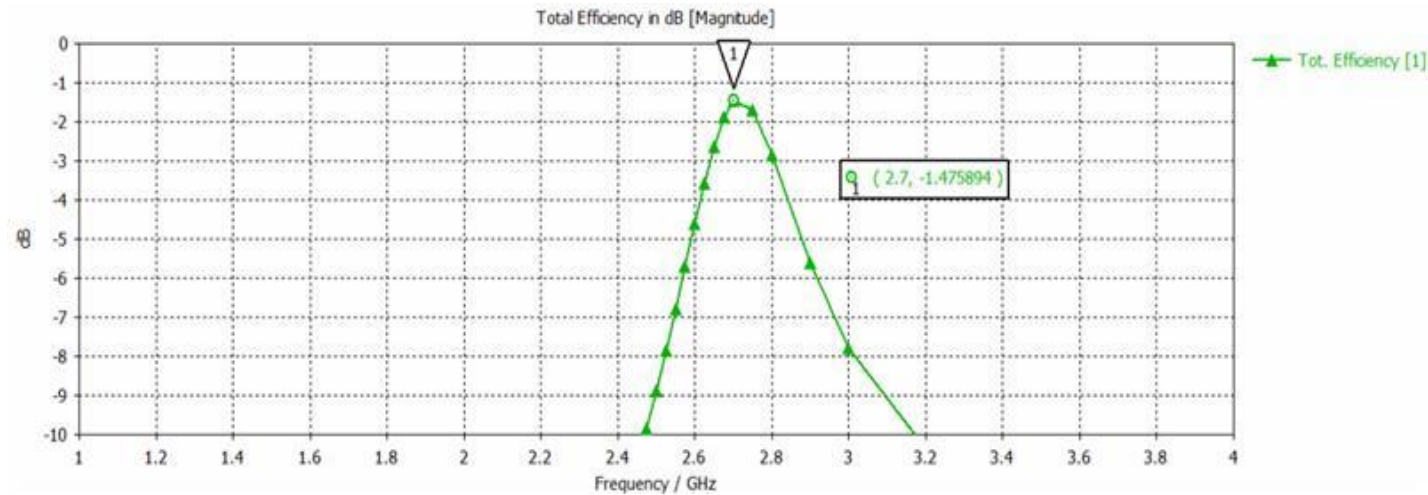
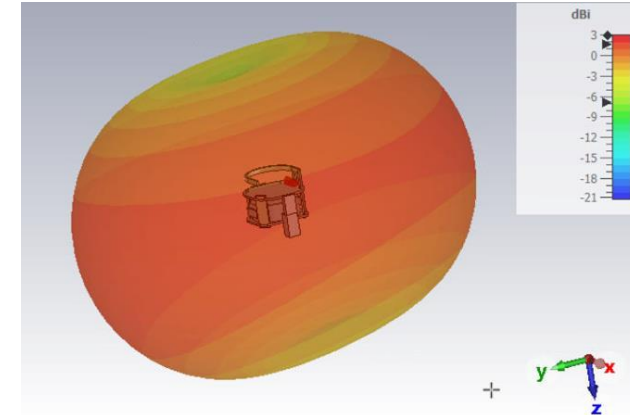
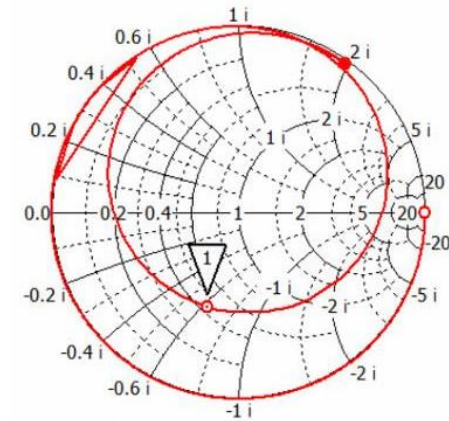
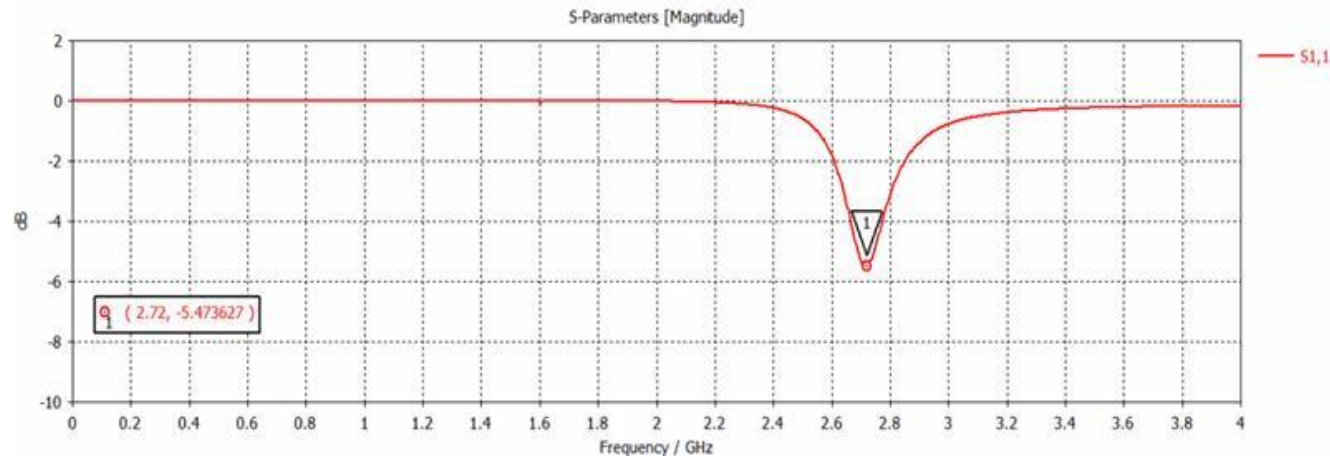

## Hörgerät Antennen Tuning

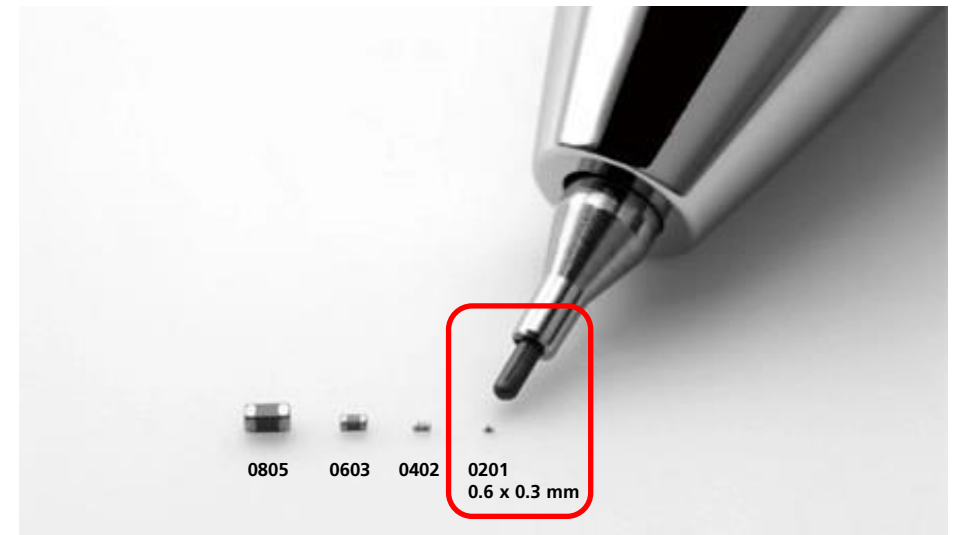
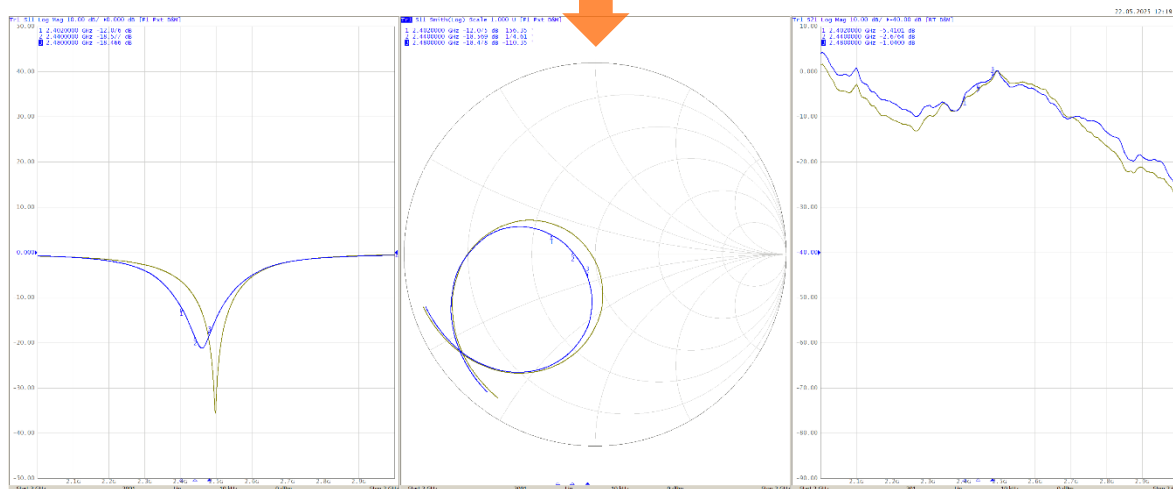
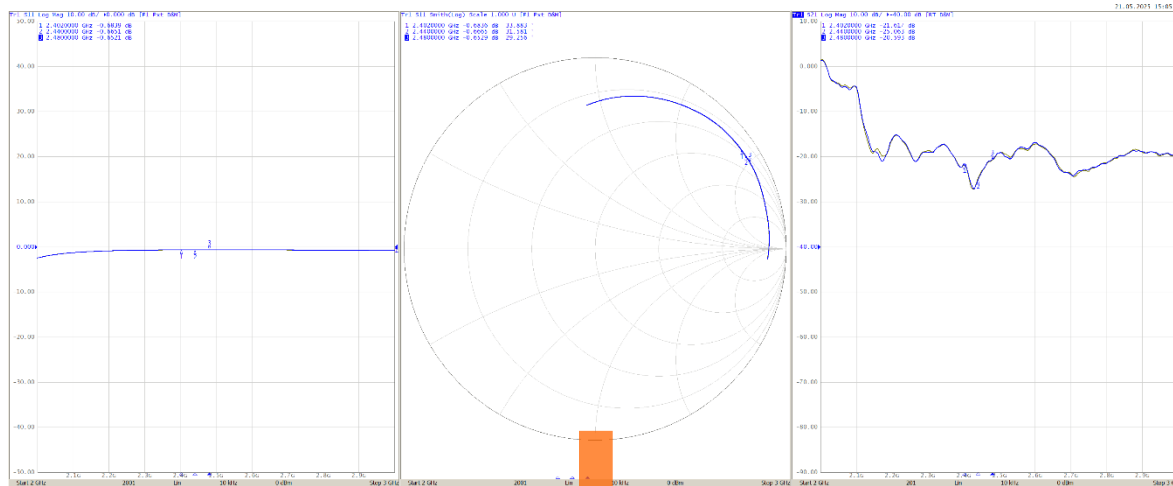

## Ladegerät

Blockschaltbild

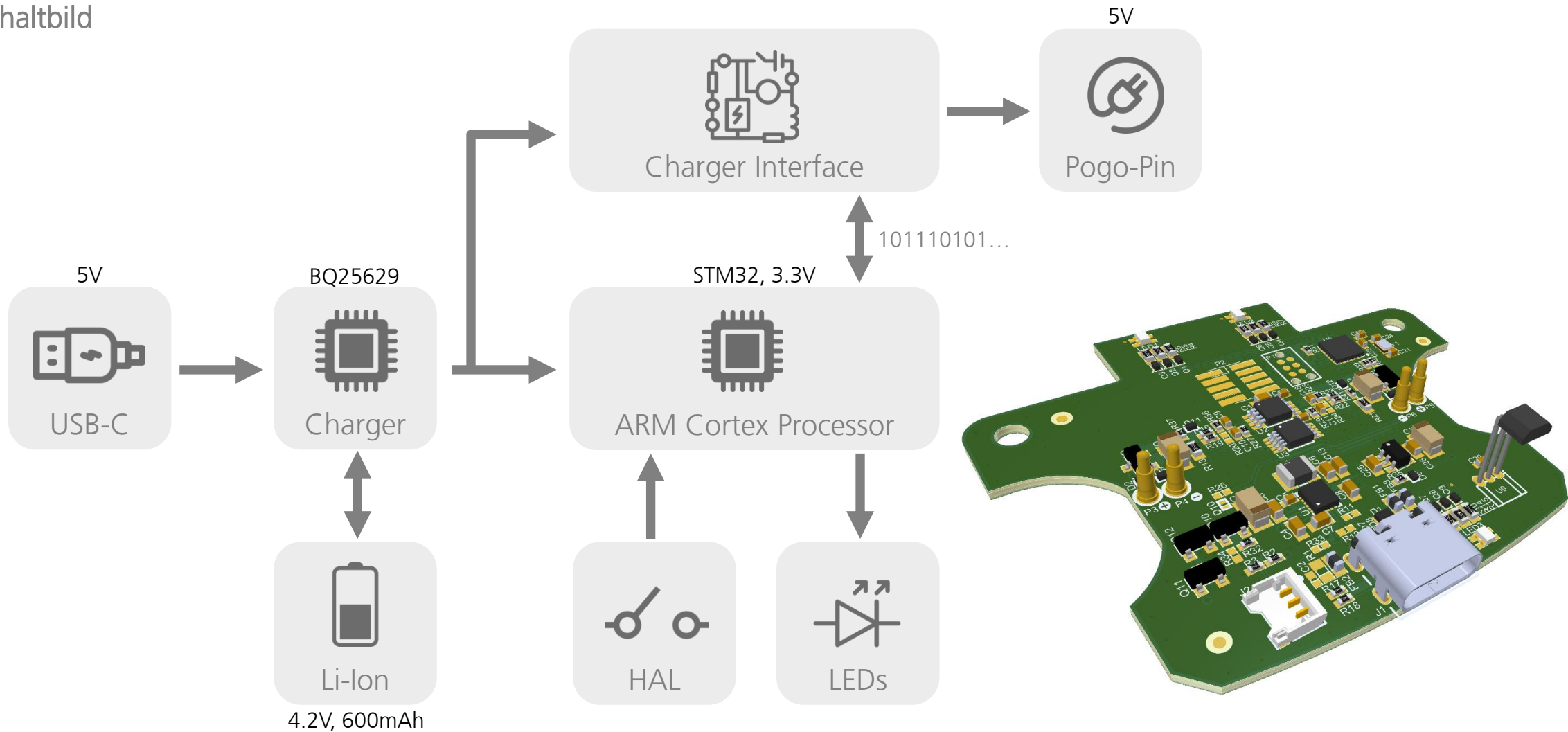

## Ladegerät

Charger Interface

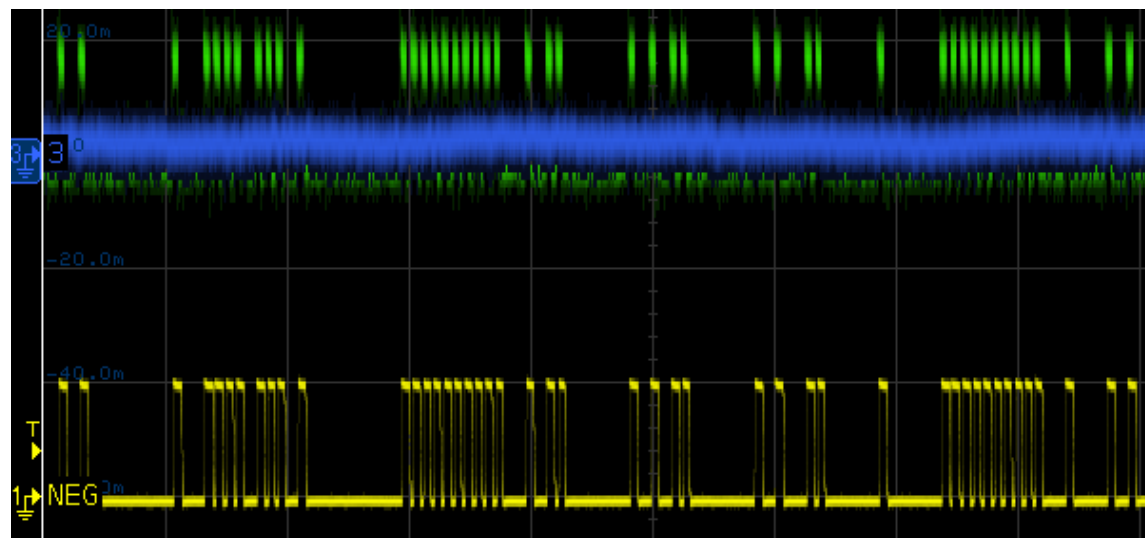
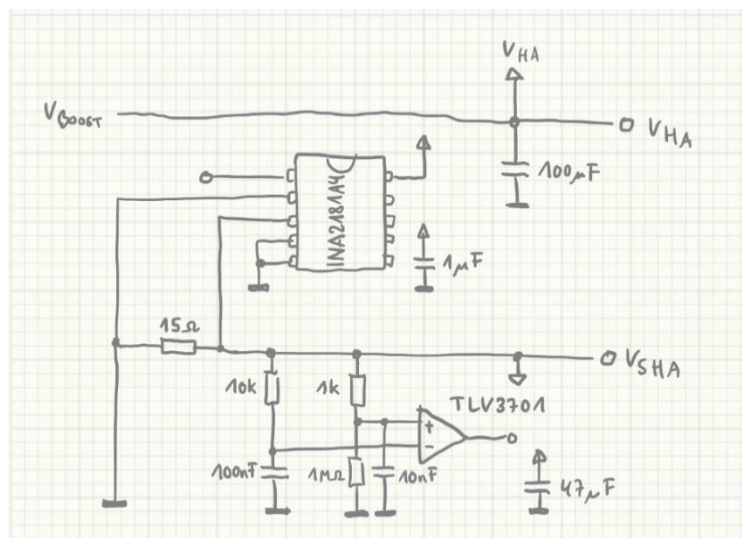
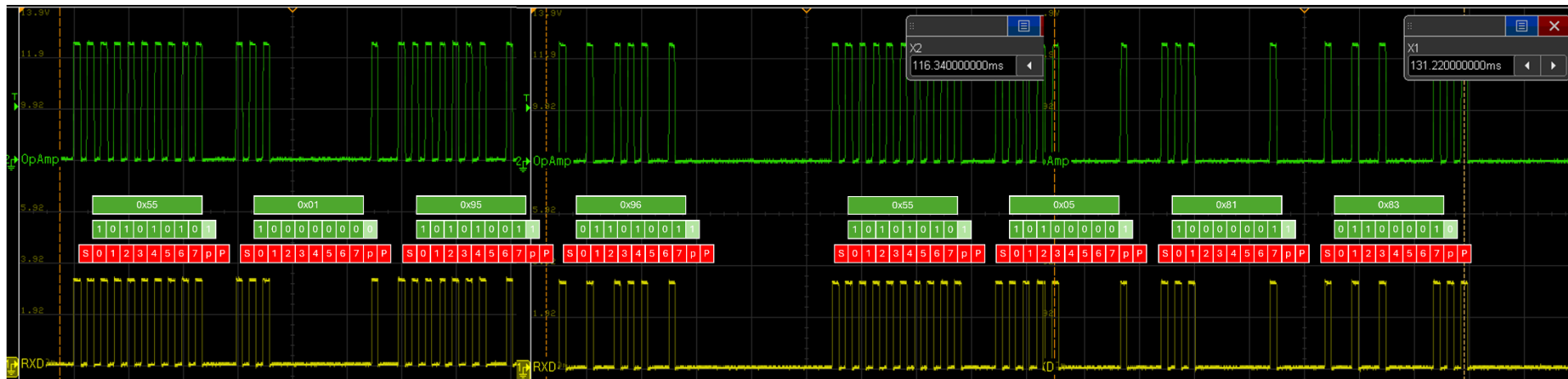

# Ladegerät

## Langzeitmessung

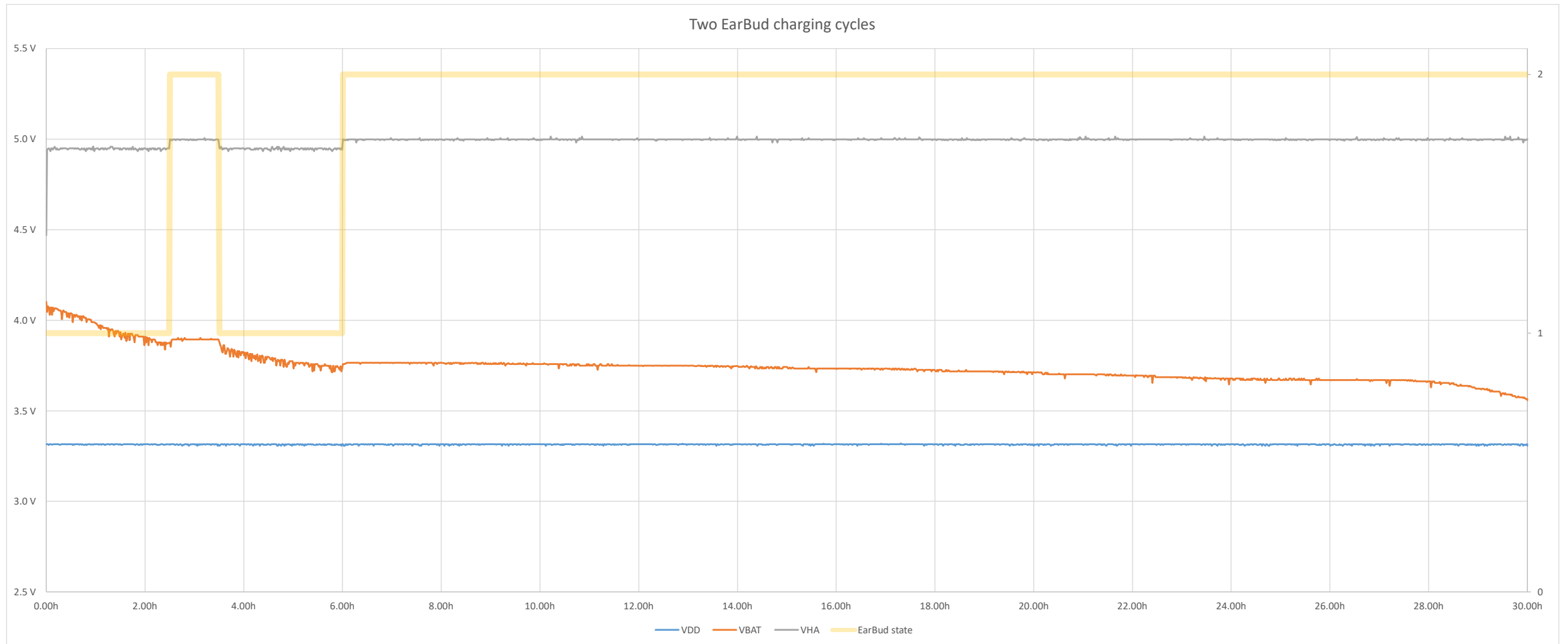

## App

Hörgeräte konfigurieren

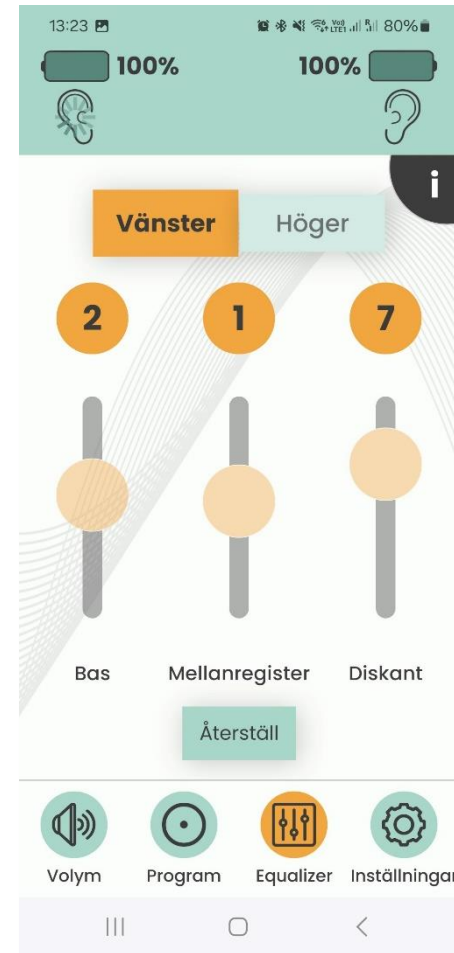
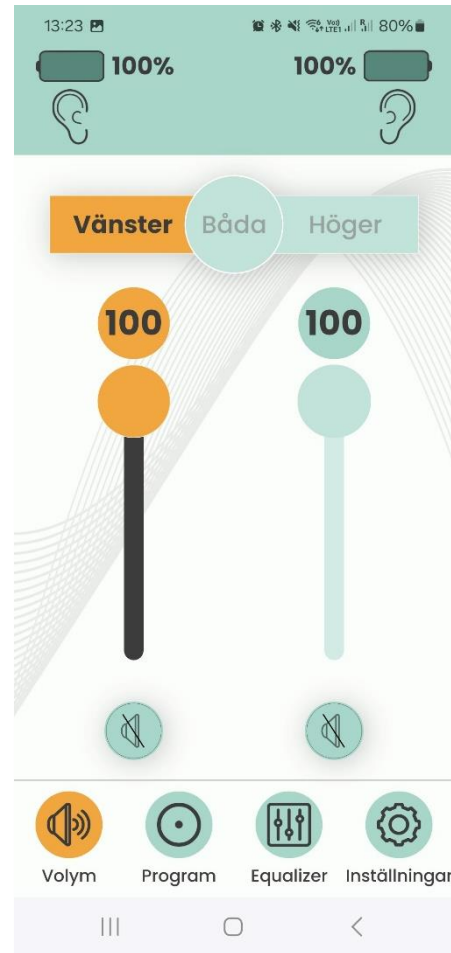

## Tools

### Programmer für Hörgeräte

```
C:\Windows\System32\cmd.exe - HPM10_OTP_Tool.exe --Promira --speed 400 -w EarBud_full.otp
Microsoft Windows [Version 10.0.19045.5611]
(c) Microsoft Corporation. Alle Rechte vorbehalten.

C:\Users\r_talib\OneDrive - Arendi AG\Desktop\HPM10_1_5\CMD\dist\HPM10_OTP_Tool.exe --Promira --speed 400 -w EarBud_full.otp
Put charger in Test Mode and verify that:

LED on HPM10 Eval Board is Lit
VBAT is connected to battery or battery emulator.
OTP-SEL = VDDP
VDDIO-SEL = DV
VMA-SEL = Jumpered
ATST_EN = VDDIO
EXT_CLK = 256kHz (0V ~ 1.8V)

Press Enter to Continue...

Generate reset on CCIF pin (pull low)

Press Enter to Continue...
```

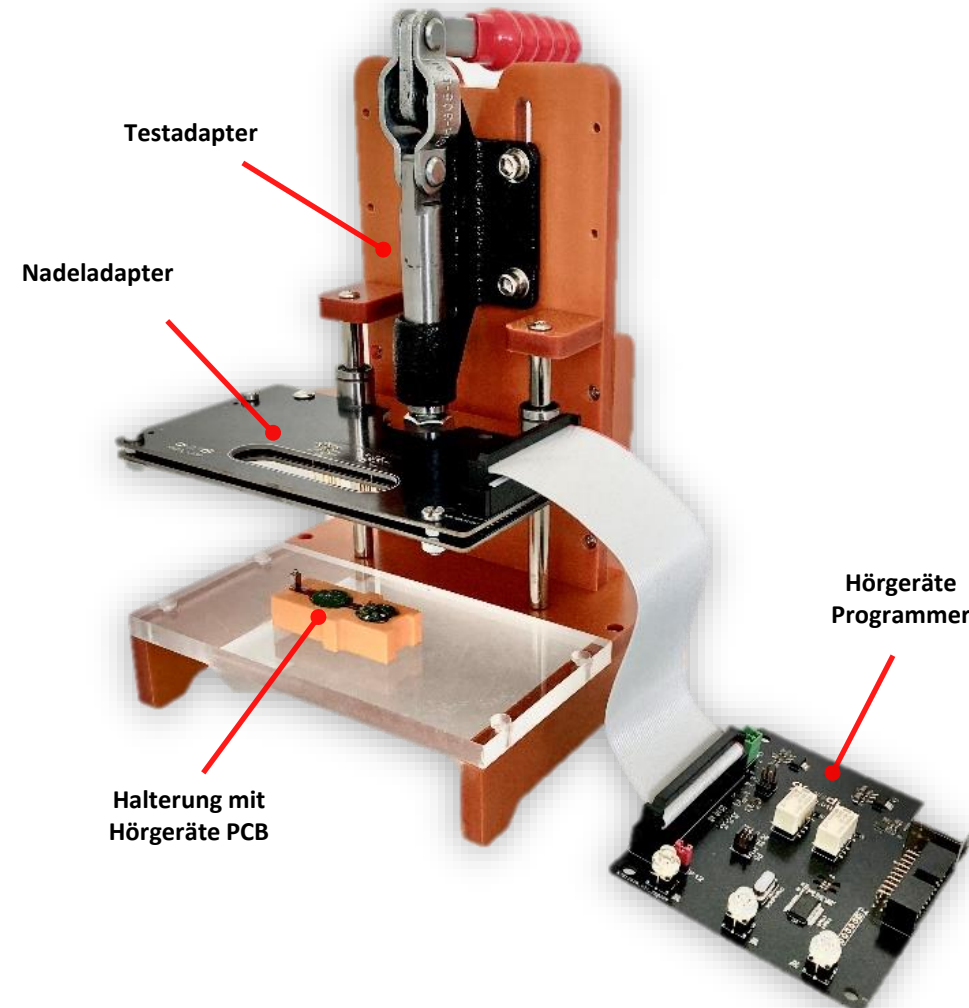

**Wir sind Ihre Lösung.**

**Arendi AG**  
Eichtalstrasse 55  
8634 Hombrechtikon  
Schweiz

**[www.arendi.ch](http://www.arendi.ch)**

r&d